

# DONNA 7

MANUAL

Pendant lamp  
Nina Jobs & Stina Sandwall  
2019

pholc

## DONNA 7

The Donna 7 lamp is reminiscent of a soft pleated textile, though in reality it's made from a fine, light aluminium. The form takes a cue from luxe, weightless fabrics used in high fashion and embraces the challenges of creating an illusion of softness, using a hard material instead of a woven textile. A beautiful and versatile piece with an expressive personality, Donna is equally at home in any environment. A sibling to the Donna pendants, this wall variation can be used independently to add character to a reading nook; or pleasing symmetry to a larger space or corridor. It comes in one size and four colourways.

## NINA JOBS & STINA SANDWALL

Based in Stockholm, Nina Jobs is the creative force behind an internationally renowned company whose outputs span product and furniture design, art direction and visual performance. Also working in Stockholm, Stina Sandwall aims to strike the balance between functionality and pure clarity of vision. Stina's accolades for her product design include "Excellent Swedish Design" and "Elle Decoration Swedish Design Award".

## PHOLC

Founded in 2015 by Maja and Samuel Norburg, Pholc is a young lighting brand with a quietly exacting philosophy. Not just another Scandinavian design company, Pholc is a distinctly Swedish atelier, evident in our desire to constantly look forward. Through our collaborations with the brightest design talent, we create versatile lighting solutions that are expressive, relevant, sophisticated, and informed.

PRODUCT	COLOR	ART
Donna 7	Linen	960 113
Donna 7	Bluch	960 114
Donna 7	Black ink	960 115
Donna 7	Autumn leaves	960 118

**EXPRESSIVE.**

**SOPHISTICATED.**

**RELEVANT.**

**INFORMED.**

## ASSEMBLY

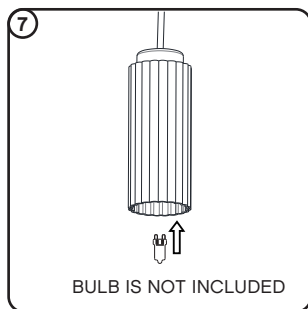
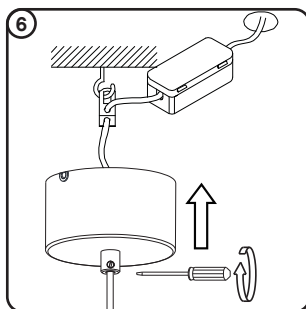
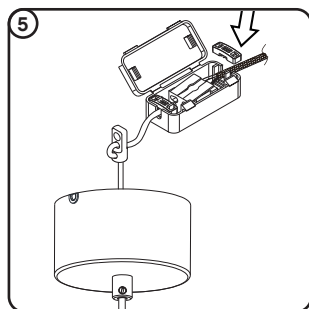
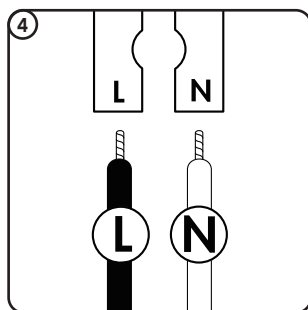
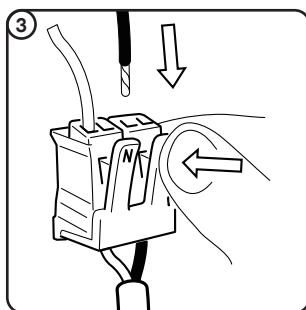
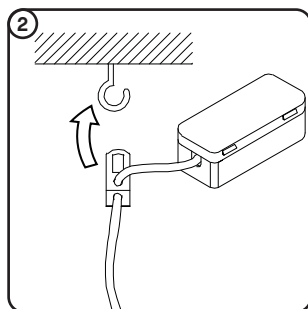
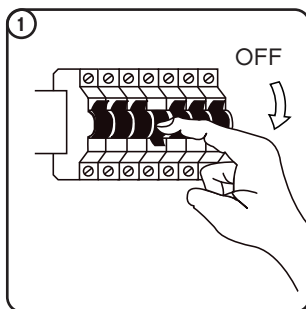
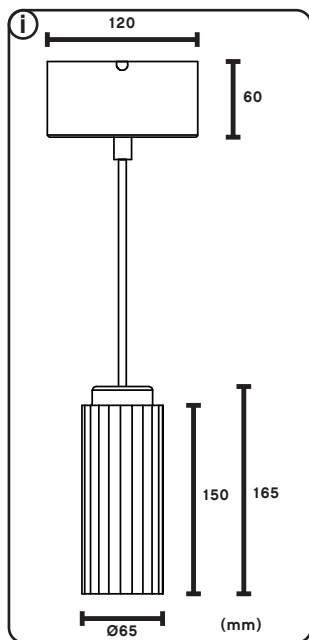

## CLEANING INSTRUCTIONS:

Wipe with a dry cloth



**EN** Installation instruction

**CAUTION: DISCONNECT POWER**

Always shut off power at the circuit breaker or disconnect fuse when installing or repairing this or any other electric appliance. Failure to do so may result in severe injury.

1. Make sure the bulb does not touch the shade
2. If the external flexible cable or cord of this lamp is damaged, it shall be exclusively replaced by the manufacturer, the service agent or a similar qualified person in order to avoid a hazard.

**SV** Installationsanvisning

**VARNING: BRYT STRÖMMEN**

Se till att lampan är spänningslös innan installationen påbörjas. Underlåtenhet att göra detta kan leda till allvarlig personskada.

1. Säkerställ att ljuskällan inte rör skärmen
2. Om sladden eller någon kabel till lampan är skadad får utbyte av delar endast utföras av person med rätt kvalifikationer för att undvika att man utsätter sig för fara.

**DE** Installationsanweisung

**VORSICHT: TRENNEN SIE DIE STROMVERSORGUNG**

Schalten sie die stromversorgung aus stellen sie sicher, dass die lampe stromlos ist, bevor sie mit der installation beginnen. Andernfalls kann es zu schweren verletzungen kommen.

1. Stellen sie sicher, dass die glühbirne den schirm nicht berührt
2. Wenn das externe flexible kabel dieser leuchte beschädigt wird, wenden sie sich ausschließlich an den hersteller, seinen kundendienst oder eine ähnlich qualifizierte person, um eine gefährdung zu vermeiden.

**FI** Asennusohje

**VAROITUS: KATKAISE VIRTA**

Ennen asennusta varmista ettei valaisimessa ole virtaa. Jos näin ei tehdä seurauksena voi olla vakavia vammoja.

1. Varmista ettei valonlähde ole kosketuksessa varjostimeen
2. Jos jokin valaisimeen kytketyistä johdoista on vahingoittunut, niin vaaran välttämiseksi vahingoittuneiden osien vaihdon saa suorittaa ainoastaan vaadittavan pätevyuden omaava henkilö.

**FR** Instructions d'installation

**MISE EN GARDE: DÉCONNECTER L'ALIMENTATION**

Coupez toujours l'alimentation au disjoncteur ou débranchez le fusible lors de l'installation ou de la réparation de cet appareil ou de tout autre appareil électrique. Ne pas le faire peut entraîner de graves blessures.

1. Assurez-vous que l'ampoule ne touche pas l'abat-jour
2. Si le câble de ce luminaire est endommagé, il doit être remplacé exclusivement par le fabricant ou par une personne qualifiée afin d'éviter tout incident.

**ES** Instrucciones de instalación

**PRECAUCIÓN: DESCONECTE LA ENERGÍA**

Siempre corte la energía en el disyuntor o desconecte el fusible al instalar o reparar este o cualquier otro aparato eléctrico. No hacerlo puede resultar en lesiones graves.

1. Asegúrese de que la bombilla no toque la pantalla
2. Si el cable exterior flexible o el cordón de esta luminaria está dañado, debe ser sustituido exclusivamente por el fabricante o en su defecto por su servicio técnico o por un profesional cualificado similar para evitar posibles riesgos.