

MEDITERRANEAN OBJECTS

www.mtobjects.com

# SUAU

## PENDANT LAMP

MODEL L800

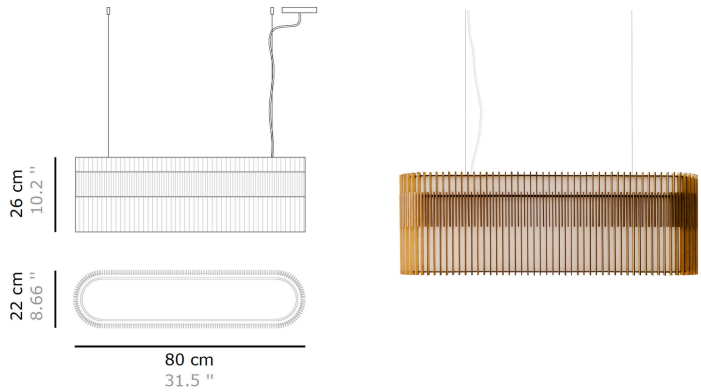

### Suau lamps Soft light, natural material.

Suau lamps have an external screen made of MDF wooden slats, laser cut and assembled one by one, in such a way that they create two different visual textures, one thicker, and the other more open.  
Another interior lampshade, diffuses the light, creating a soft atmosphere and pleasant ambient light.

Las lámparas Suau tienen una pantalla exterior de listones de madera MDF, cortados con láser y ensamblados uno a uno, de forma que crean dos texturas visuales diferentes, una más gruesa y otra más abierta.  
Otra pantalla interior, difumina la luz, creando una atmósfera suave y una agradable luz ambiental.

Les lampes Suau sont dotées d'un écran extérieur composé de lattes de bois MDF, découpées au laser et assemblées une à une, de manière à créer deux textures visuelles différentes, l'une plus épaisse et l'autre plus ouverte.  
Un autre abat-jour intérieur diffuse la lumière, créant une atmosphère douce et une lumière ambiante agréable.

#### MATERIALS & FINISHES | MATERIALES Y ACABADOS | MATÉRIAUX ET FINITIONS

Natural mdf wood lampshade. Textile cable. Flat metal ceiling rose in white color.

Pantalla de madera mdf natural. Cable textil. Soporte de techo metálico en color blanco.

Abat-jour en bois mdf naturel. Câble textile. Plaque de plafond en métal plat de couleur blanche.

#### BULB | BOMBILLA | AMPOULE

LED strip 10W 1056 Lm - 3000°K



Interior use only.

Solo uso interior.

Usage intérieur uniquement.



➔ 100 x 26 x 37 cm

#### WEIGHT | PESO | POIDS

lamp | lámpara | lampe

2 kg

Approximate weights

#### MAINTENANCE | MANTENIMIENTO | ENTRETIEN

Clean gently with a soft cloth, slightly moistened with water. Do not use detergents, ammonia or abrasive products.

Limpiar delicadamente con tela suave, ligeramente humedecida con agua. No utilizar detergentes, amoníaco, o productos abrasivos.

Nettoyer délicatement avec un chiffon doux, légèrement humidifié avec de l'eau. Ne pas utiliser de détergents, d'ammoniaque ou de produits abrasifs.

#### OTHER SIMILAR MODELS | OTROS MODELOS SIMILARES | AUTRES MODÈLES SIMILAIRES

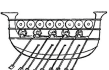

MEDITERRANEAN OBJECTS

Barcelona, Spain - www.mtobjects.com - info@mtobjects.com - 05.2024

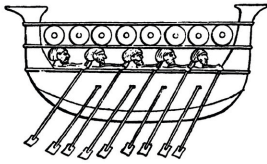

Bringing beauty into the world

## MEDITERRANEAN OBJECTS

Lamps designed and produced by hand in Barcelona.  
Handmade and with natural materials.

## INSTRUCTIONS INSTRUCCIONES INSTRUCTIONS

# SUAU

## PENDANT LAMP

MODEL L1000

### Content

Contenido

Contenu

x1

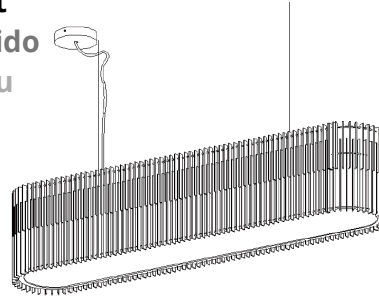

x2



x4



x4



### INSTRUCTIONS

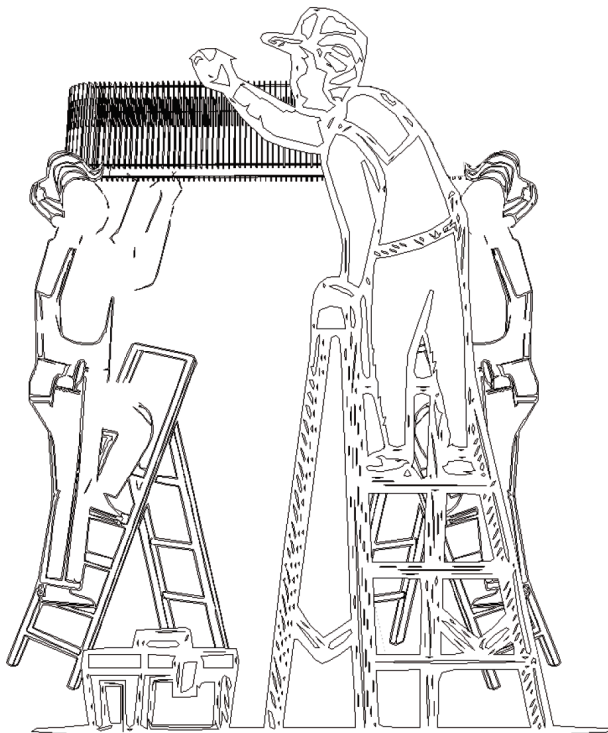

### Warning !

**The wood screen must be handled with special care to avoid damaging the wood.**

If any of the wooden slats should come off during transport or installation, please reattach them to the structure using the "Repair kit".

It is recommended to keep the lamp protected with the protective bubble roll until it has been hung from the ceiling.

### Advertencia !

**La pantalla de madera debe manipularse con especial cuidado para evitar dañar la madera.**

Si alguno de los listones de madera se desprendiera durante el transporte o la instalación, vuelva a fijarlo a la estructura utilizando el "Kit de reparación".

Se recomienda mantener la lámpara protegida con el rollo protector de burbujas hasta que haya sido colgada del techo.

### Attention !

**L'écran en bois doit être manipulé avec un soin particulier pour éviter d'endommager le bois.**

Si l'une des lattes de bois se détache pendant le transport ou l'installation, il faut la rattacher à la structure à l'aide du "Kit de réparation".

Il est recommandé de protéger la lampe avec le rouleau à bulles jusqu'à ce qu'elle soit suspendue au plafond.

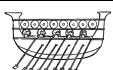

## INSTRUCTIONS

**01**

Mesasurements for anchoring the metal tensioning cables to the ceiling:

Medidas para anclar los tensores metálicos al techo:

Mesures pour l'ancrage des câbles de tension métalliques au plafond:

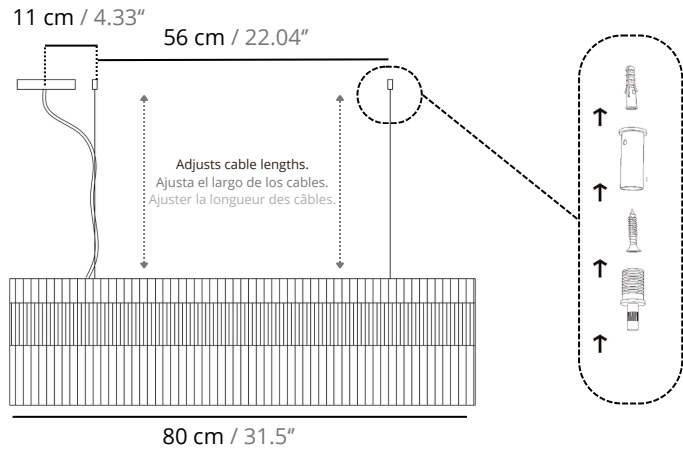

Once the lamp is firmly fastened to the ceiling by the two metal tensors, proceed to connect it to the electric current.

Una vez que la lámpara esté firmemente sujeta al techo por los dos tensores metálicos, proceda a conectarla a la corriente eléctrica.

Une fois la lampe solidement fixée au plafond par les deux tenseurs métalliques, procédez au raccordement au courant électrique.

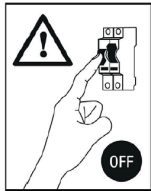

**02**

N: Blue  
L: Brown  
PE: Green & Yellow

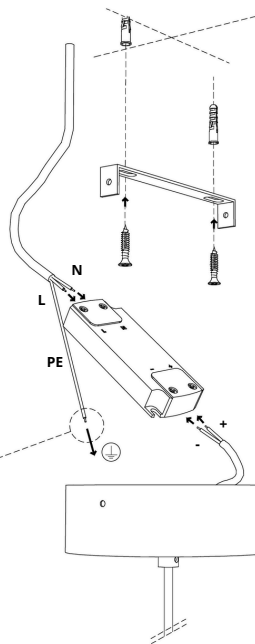
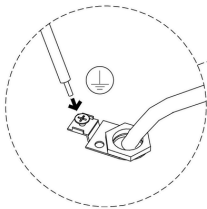

**03**

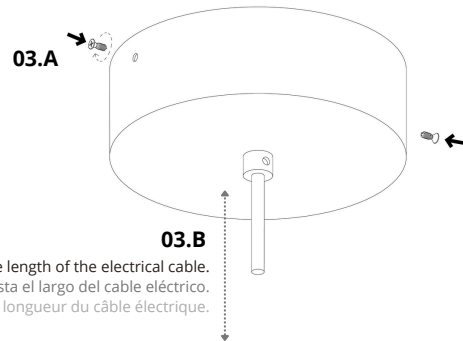

Included:  
Incluido:  
Inclus:  
LED strip 10W 1056 Lm - 3000°K

