



Sammode

MONDRIAN

Notice de montage

Mounting instruction / Montageanweisung

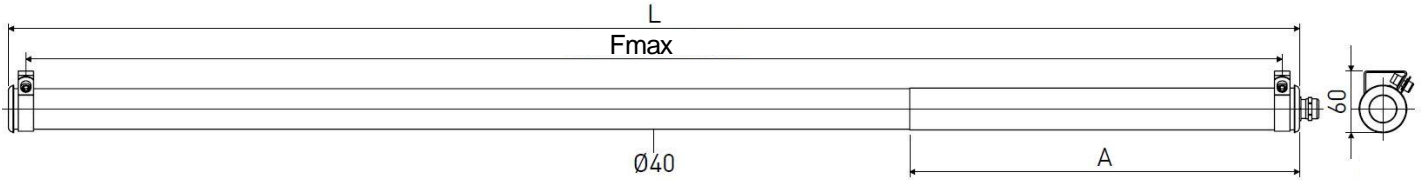

	(Lm)	L (mm)	Fmax (mm)	A (mm)	(V)	(kg)
Mondrian (180°)	1000	988	958	355	220-240V AC	0,8
	1500	988	958	355	220-240V AC	0,8
	1500	1250	1220	355	220-240V AC	1,1
	2000	1250	1220	355	220-240V AC	1,1
Mondrian (260°)	350	623	593	195	24V DC	0,4
	350	623	593	195	220-240V AC	0,5
	500	988	958	355	220-240V AC	0,8
	900	1250	1220	355	220-240V AC	1,1

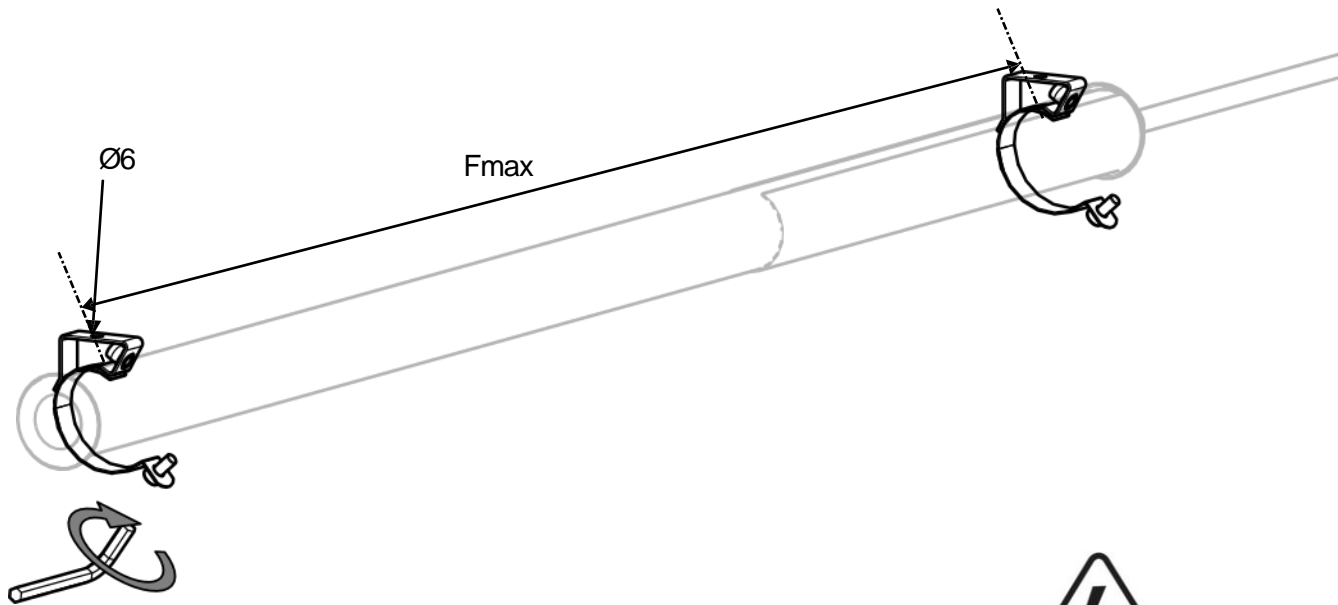

Ne pas ouvrir sous tension
Do not open when energized
Nicht unter Spannung öffnen

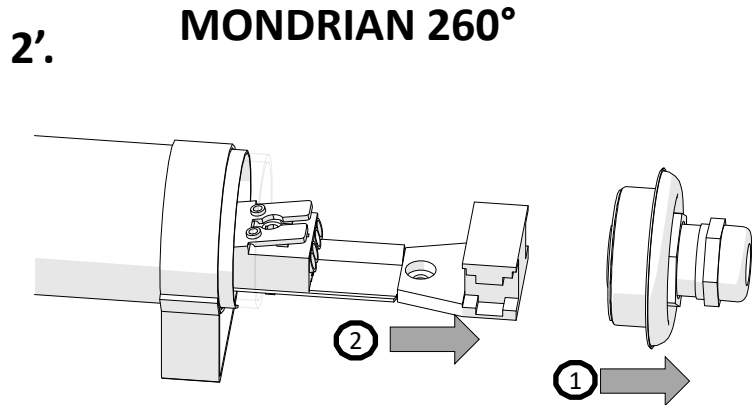
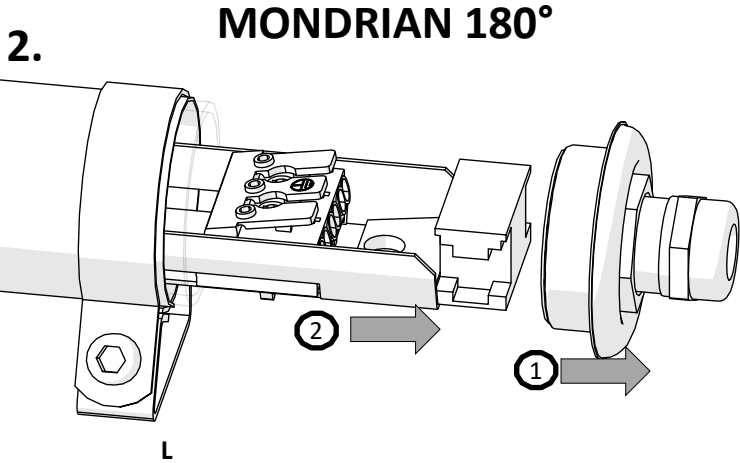
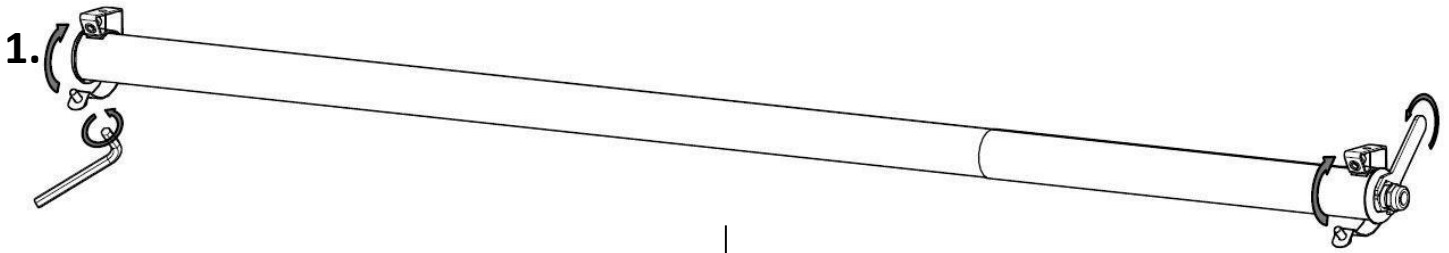
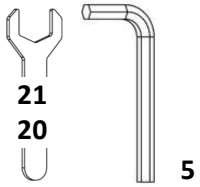

	A	B
1-1.5 mm ²	8 mm	12 mm
2.5 mm ²	12 mm	12 mm

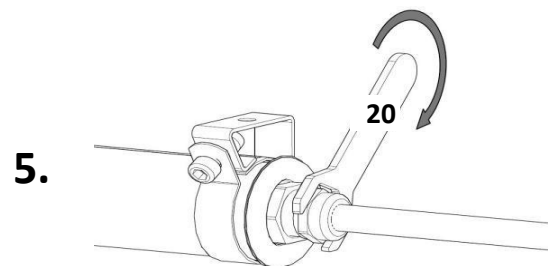
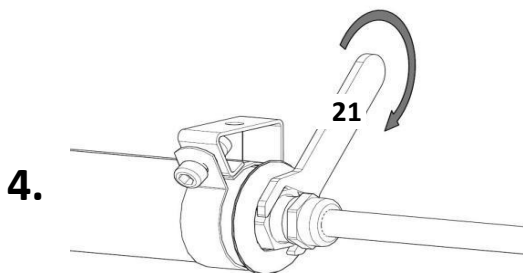
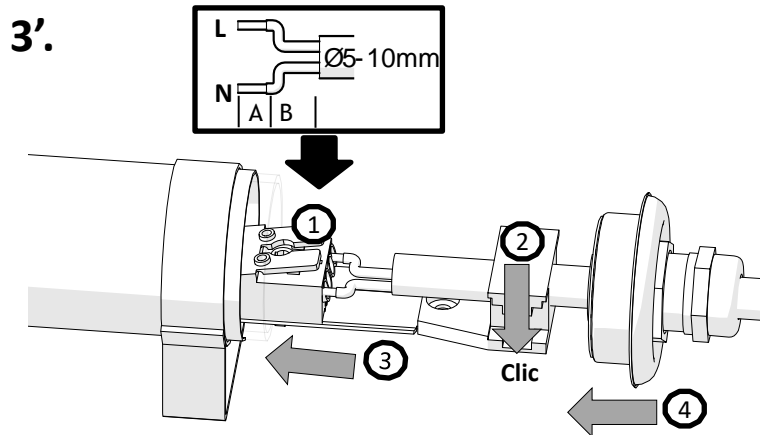
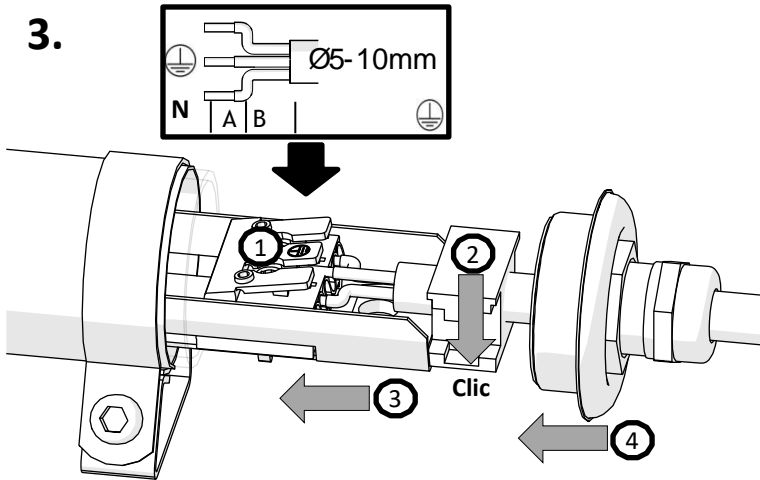

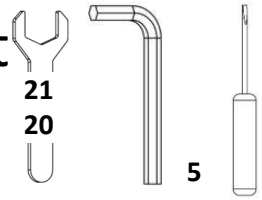

MONDRIAN 260° 24V DC

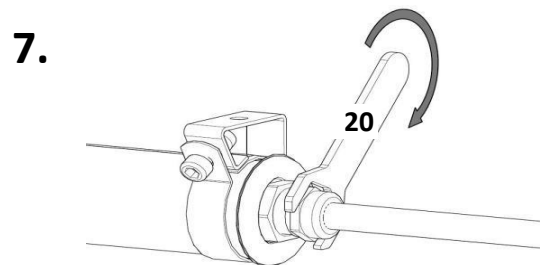
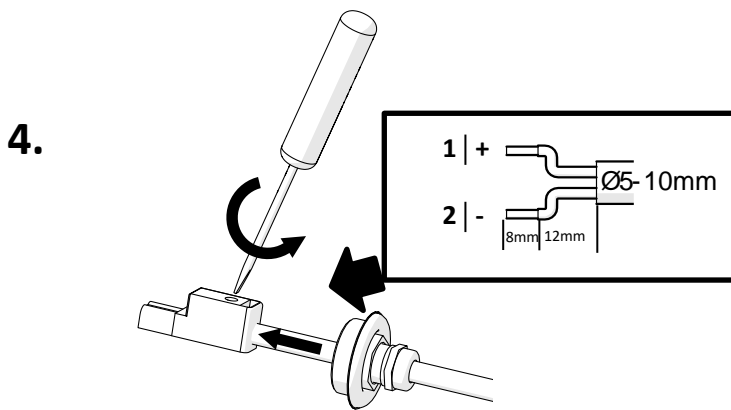
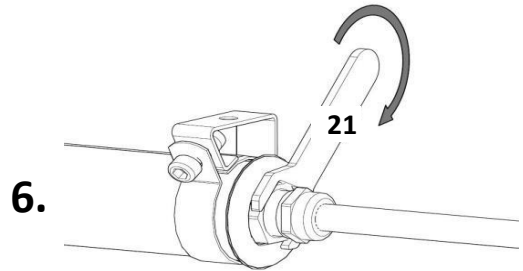
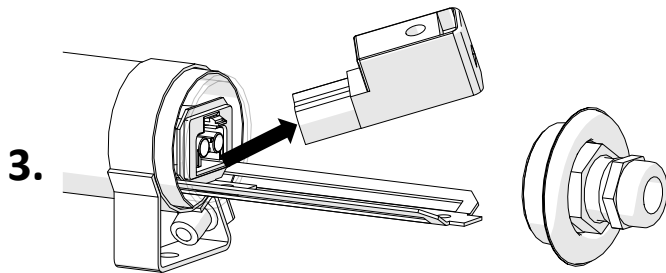
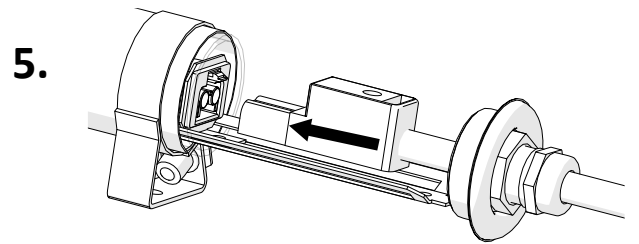
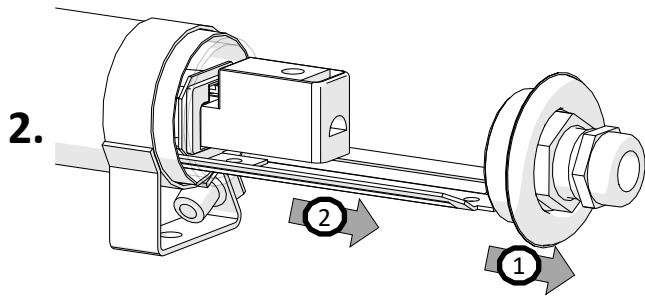
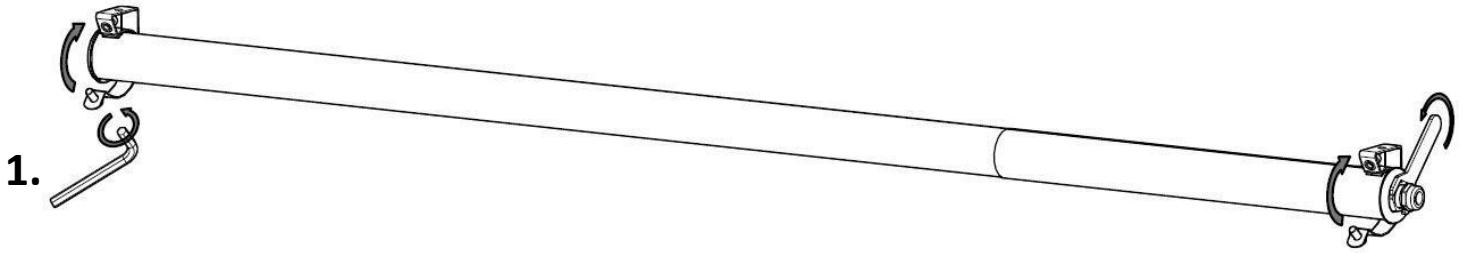



MONDRIAN 260° 24V DC

Utilisez un convertisseur d'alimentation très basse tension de sécurité TBTS avec $V_{out} \max = 24V \text{ dc}$, conforme à IEC / EN 61347-2-13 ou IEC / EN 61558-2-1, protégé contre les courts-circuits

Only use SELV safety extra low voltage power supplies with $V_{out} \max = 24V_{dc}$, compliant with IEC / EN 61347-2-13 or IEC / EN 61558-2-1, protected against short circuit

Vervenden sie SELV-Schutzkleinspannung Netzteile mit $V_{out} \max = 24V_{dc}$, konform mit IEC / EN 61347-2-13 oder IEC / EN 61558-2-1, gegen Kurzschluss geschützt.



1. Position & câble / Position & cable / Position & kabel

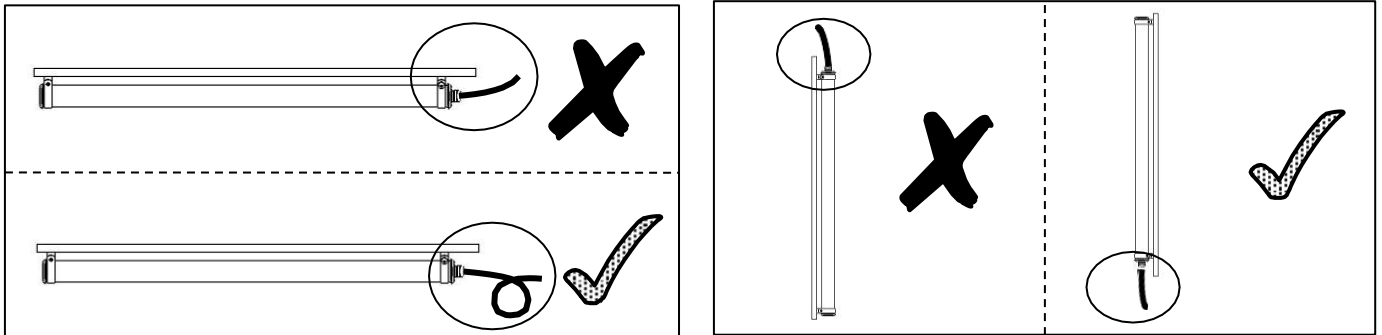

2. Flasques / End caps / Endkappen

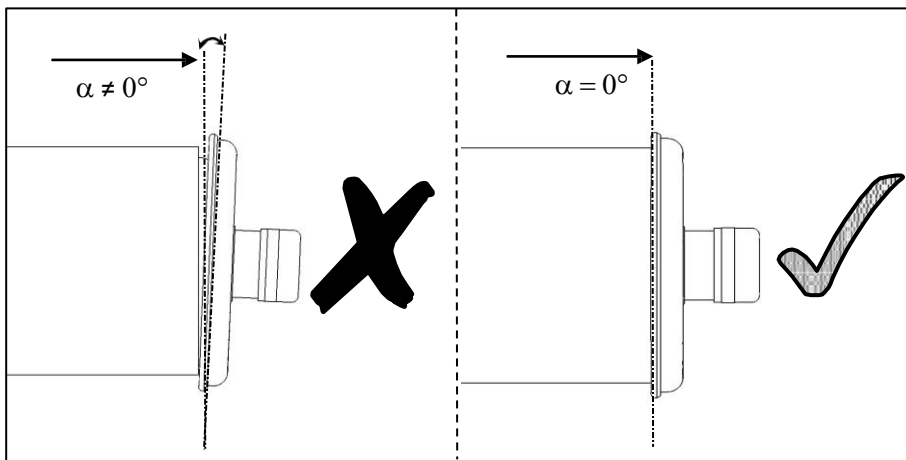

3. Vis centrale / Central screw / Zentrale schraube

