

LX PLATINE : ÉDITION SPÉCIALE SUPAKITCH

LX TURNTABLE : SPECIAL EDITION SUPAKITCH

CONNECTIVITÉ

CONNECTIVITY



BLUETOOTH APT-X®



MINI-JACK 3,5 MM



PRÉAMPLIFICATEUR PHONO
INTÉGRÉ
RCA PHONO BUILT-IN
PREAMP



MULTI-ROOM COMPATIBLE



OPTIQUE
OPTICAL



2 X USB OUTLET

TECHNOLOGIE

TECHNOLOGY



WIDE SOUND® 3.0

**315
WATTS**

PUISSANCE 315W
POWER 315W

5 x

HAUT-PARLEURS EXCLUSIFS
EXCLUSIVE SPEAKERS



TOUT-EN-UN
ALL IN ONE



COMPATIBLE
CHARGE À INDUCTION
WIRELESS CHARGING
COMPATIBLE



DAC USB 24 BITS

WIDE SOUND® 3.0

UN ORCHESTRE LIVE DANS
UN VOLUME COMPACT

A LIVE ORCHESTRA
IN A COMPACT UNIT

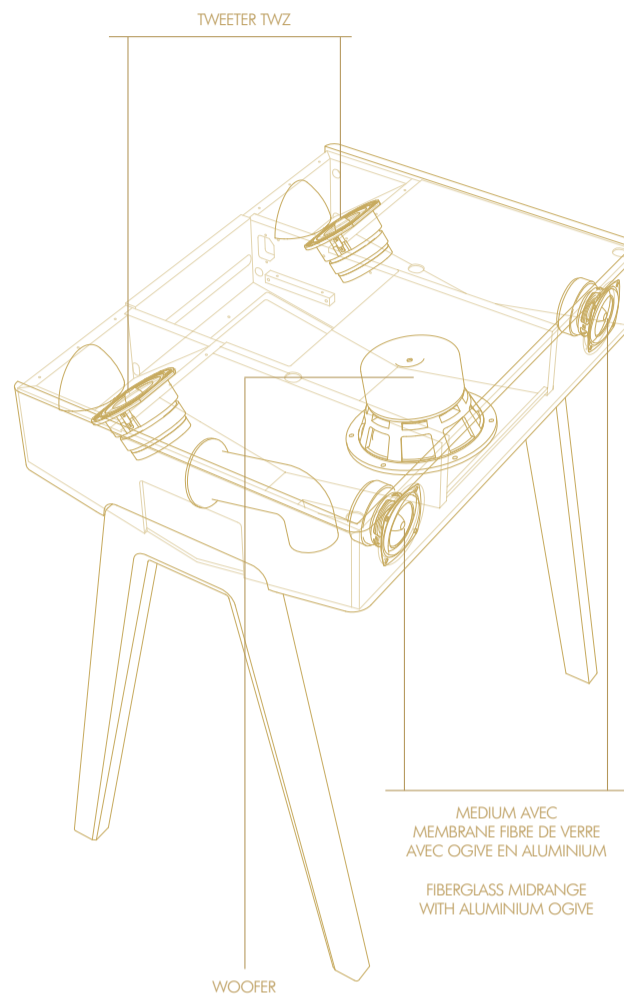

LX PLATINE SUPAKITCH

NOYER / WALNUT

L69 x L48 x h79

■ Noyer (Walnut)



LX PLATINE SUPAKITCH

NOIR / BLACK

L69 x L48 x h79

■ Bois brûlé (Burned wood)

■ Noir mat (Matte black)

UN OBJET SCULPTURAL ET MOUVANT.

A NEW SOUND OBJECT BOTH, SCULPTURAL AND MOVING.

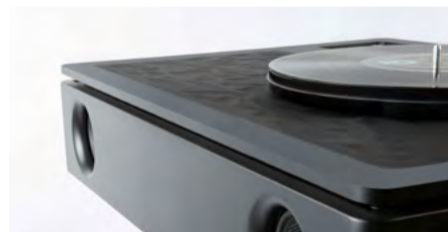

STORY

Pour cette nouvelle collaboration, l'artiste SupaKitch ré-interprète l'enceinte orchestrale LX Platine en apportant à sa surface des reliefs liquides faisant écho à son travail sur l'onde aquatique.

La matière liquide est au cœur de l'inspiration de l'artiste. En figeant le mouvement liquide, SupaKitch propose en réalité des œuvres en mouvement perpétuel. C'est l'association de ce mouvement de forme et de son qui donne son sens à ce nouvel objet sonore, sculptural et mouvant.

For this new collaboration, the artist SupaKitch re-interprets the LX Turntable orchestral loudspeaker by bringing to its surface liquid reliefs echoing his work on the aquatic wave.

Liquid matter is at the heart of the artist's inspiration. By freezing the liquid movement, SupaKitch actually proposes works in perpetual motion. It is the association of this movement of form and sound that gives meaning to this new sound object both, sculptural and moving.

SAVOIR-FAIRE D'EXCELLENCE

Le plateau de cette édition spéciale est gainé d'un cuir pleine fleur Bleu Smoke aux reliefs évoquant ceux de la surface de l'onde. Ce cuir de taurillon à la qualité exceptionnelle provient de la tannerie Remy Carriat, au Pays Basque, il est ensuite découpé au laser et appliqué sur les plateaux dans les Landes, le piètement en bois est comme toujours fabriqué par nos ébénistes au Pays Basque espagnol et enfin l'enceinte est assemblée à Ustaritz au Pays Basque français dans notre atelier.

KNOW-HOW OF EXCELLENCE

The top of this special edition is sheathed in a Smoke Blue full grain leather with reliefs evoking those of the surface of the wave. This bull calf leather of exceptional quality comes from the Remy Carriat tannery in the Basque Country, it is then laser-cut and applied to the tops in the Landes, the wooden base is as always made by our cabinetmakers in the Spanish Basque Country and finally the speaker is assembled in Ustaritz in the French Basque Country in our workshop.

www.laboiteconcept.com

Supakitch

Guillaume Grando (alias SupaKitch) est un artiste pluridisciplinaire français au rayonnement international.

Né en banlieue Parisienne en 1978, il débute très jeune le graffiti. Cette approche graphique marquera l'ensemble de son œuvre. L'artiste croise les influences d'une adolescence rythmée par le hip-hop, le design, l'architecture et la board culture. Aujourd'hui, son travail de recherche formelle se concentre sur l'essence-même du geste, du mouvement, de la lumière et de la matière qui deviennent des questionnements centraux de son approche, fortement influencée par l'expérience du surf, dépouillés de tout superflu pour qu'il n'en reste que l'expression de l'ondulation.

SupaKitch

Guillaume Grando (a.K.a SupaKitch) is a French multidisciplinary artist with an international reputation. Born in the Paris suburbs in 1978, he started graffiti at a very young age. This graphic approach will mark the whole of his work. The artist combines the influences of a childhood brought up on manga and an adolescence punctuated by hip-hop, design and architecture as well as board culture. Gestures, movement, light and matter gradually become central questions in his approach, strongly influenced by his passion for surfing. Today, his formal research work focuses on the essence of movement: its color, its material, its reflection, stripped of all superfluity so that it remains only the expression of the undulation.



Photos : © Olivier Boulet

LX

SUPAKITCH

SPECIAL EDITION



LA BOITE
CONCEPT