

A-3730

493037309

Metallic wall lamp with acrylic diffuser and integrated LED providing direct or indirect light. It can be mounted facing up or facing down.

Aplique metálico con difusor acrílico y LED integrado que proporciona luz directa o indirecta. Se puede montar con la luz hacia arriba o hacia abajo.

**La fuente de luz de esta luminaria no es reemplazable. Cuando la fuente de luz alcance el final de su vida, debe ponerse en contacto con el fabricante para su reparación.**

230V

F.P Tiende a 1

**The light source of this luminaire is not replaceable. Once the light source's lifecycle ends, you may contact the manufacturer.**

230V

P.F Tends to 1

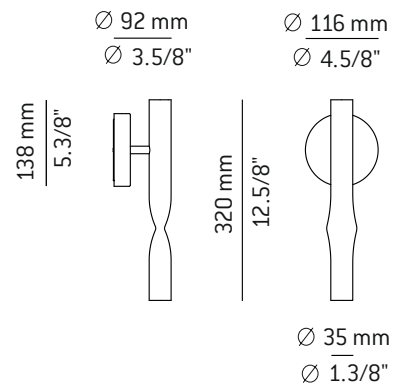

WE RECOMMEND READING THE INSTRUCTIONS ENTIRELY BEFORE STARTING YOUR INSTALLATION  
PLEASE SAVE THESE INSTRUCTIONS SO THAT YOU CAN REFER TO THEM A LATER TIME

\* Make sure the power has been disconnected before installing the fixture.

\* Lighting fixtures should be installed only by qualified personnel.

\* Assure yourself that the bulb never exceeds the maximum wattage specified on the label.

\* For indoor use only.

\* Do not use alcohol or solvents to clean the lamp

\* For your convenience, assembly by two people is recommended.

LE RECOMENDAMOS LEA LAS INSTRUCCIONES ANTES DE PROCEDER A LA INSTALACIÓN  
GUARDE LAS INSTRUCCIONES PARA FUTURAS REFERENCIAS

\* Asegúrese de que la corriente está desconectada antes de conectar el aparato.

\* El montaje de luminarias debe ser efectuado solamente por personal técnico.

\* No utilizar bombillas con potencia superior a la indicada en la etiqueta.

\* Únicamente para uso en interiores.

\* Para limpieza no utilizar alcohol ni disolventes

\* Recomendamos la intervención de 2 personas para el montaje de la lámpara

## Warning

Do not look directly into any LED source.

This lamp must be installed by a certified electrician.

## Atención

No mirar directamente a los LED.

Esta lámpara debe ser instalada por un profesional.

## Assembly instructions / Instrucciones

- 1 - Unscrew the upper screw (A) and separate the canopy (B) from the mounting bracket (C).

Figure 1.

- 1 - Desenroscar el tornillo superior (A) del tapapared (B) y liberar la sujeción (C).

Figura 1.

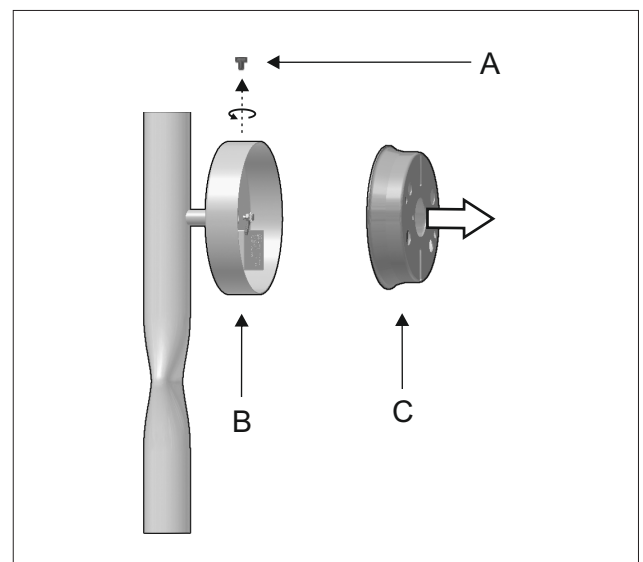

Figure 1

2A - WITHOUT JUNCTION BOX (INTERNATIONAL)

Insert the power cables (D) through the central hole of the mounting bracket (C) and fix it to the wall. Connect the electrical wires.

Figure 2A.

2A - SIN CAJA DE CONEXIONES (INTERNACIONAL)

Introducir los cables de la red (D) por el agujero central de la sujeción (C) y fijarla a la pared. Realizar las conexiones eléctricas.

Figura 2A.

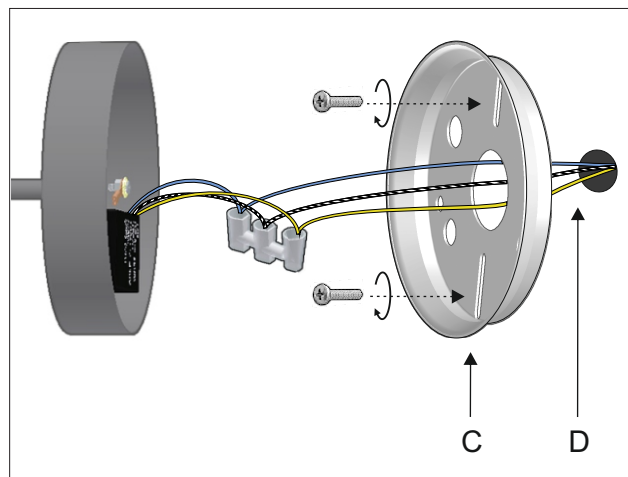

Figure 2A

2B - WITH JUNCTION BOX (USA)

Insert the electrical wires (E) through the central hole of the mounting bracket (C) and make the connections inside of the junction box (F). Fix the mounting bracket to the junction box.

Figure 2B.

2B - CON CAJA DE CONEXIONES (USA)

Pasar los cables de eléctricos (E) por el agujero central de la sujeción (C) y realizar las conexiones dentro de la caja de conexiones (F). Fijar la sujeción a la caja de conexiones.

Figura 2B.

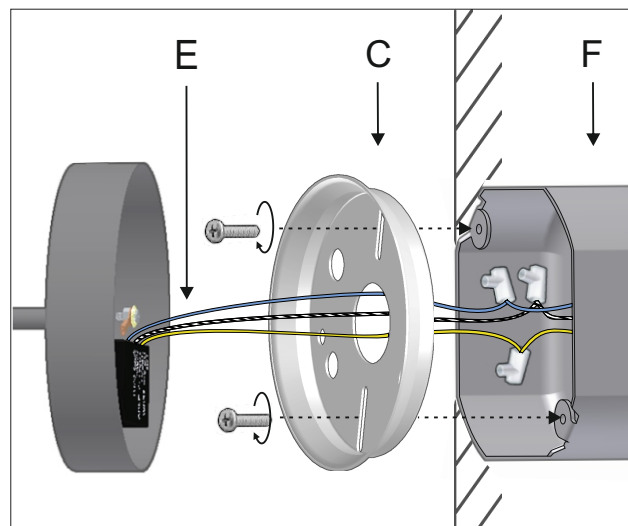

Figure 2B

3 - Attach the canopy (B) back to the mounting bracket (C) and fix it with the screw (A) that was previously removed.

Figure 3.

3 - Volver a colocar el tapapared (B) en la sujeción (C) y fijarla con el tornillo (A) liberado anteriormente.

Figura 3.

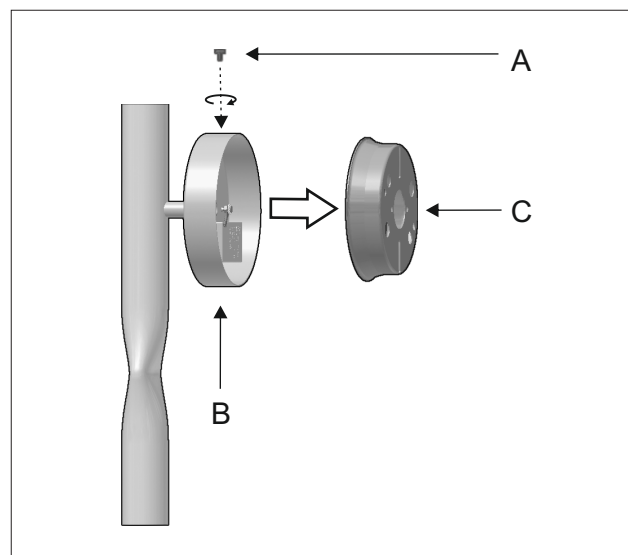

Figure 3